

**LIGHT
SOURCE**

COMPACT 2W XENON FLASH LAMP MODULES

L13651 / L13821 SERIES



OVERVIEW

The L13651 / L13821 series are 2 W xenon lamp module integrated with a power supply and a trigger socket. The lamp modules are the world's smallest in its wattage class and so gives a high degree of design freedom. The lamp modules operates on 5 V battery, making it suitable for assembly into portable analysis instruments. Other features include high stability, long life, and high luminous efficiency per flash, allowing highly accurate analysis and testing.

FEATURES

- **Compact size (world's smallest *)**
- **Operates on 5 V mobile battery**
- **High stability: 0.4 %CV Typ.**
- **Long life: 1×10^9 flashes**
- **Repetition rate: 1250 Hz Max.**
- **Broad spectrum: UV to middle IR**

* By our research (as of September 2016)

APPLICATIONS

- **Spectroscopic analysis**
- **Blood analysis**
- **Environmental analysis**
 - Water pollution analysis (TOC, TN, etc.)
 - Air pollution analysis (NO_x, SO_x, etc.)
 - Gas analysis (CH₄, etc.)

Extracting full performance from the xenon flash lamp

Easy to handle lamp modules

L13651 series



Standard type



SMA fiber adapter type

The L13651 series is an easy-to-handle, single-package lamp module designed to extract the full performance from the xenon flash lamp. The L13651 series ensures low electromagnetic noise and operates on a 5 V mobile battery, making equipment design easier. The L13651 series standard type offers amazingly high electrode positioning accuracy to ± 0.05 mm making it ideal for applications requiring even higher performance of the equipment. The L13651 series also includes an SMA fiber adapter type needing no lens design work.

TYPE NUMBER GUIDE

L13651 - A B

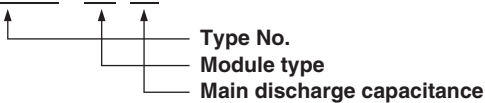

A: Module type

Suffix	Type
0	Standard type
1	SMA fiber adapter type

B: Main discharge capacitance

Suffix	Capacitance
1	0.141 μF
2	0.094 μF
3	0.047 μF
4	0.02 μF

SPECTRAL IRRADIANCE (Typ.)

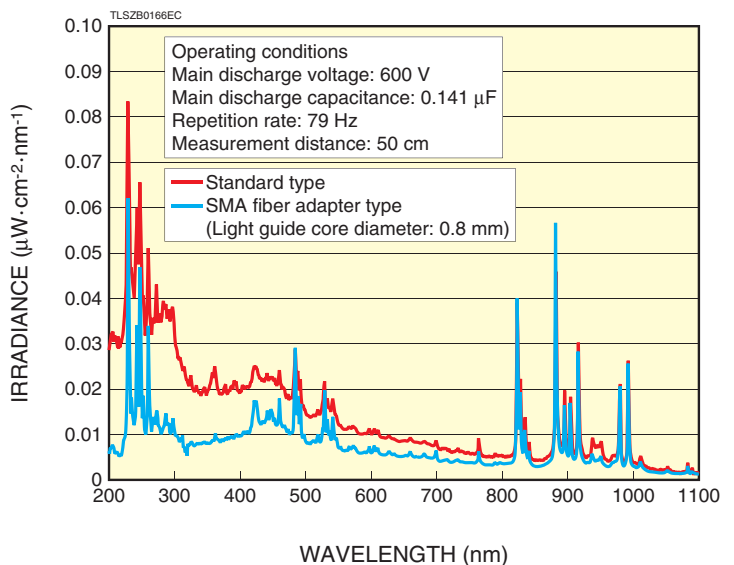

SPECIFICATIONS

Parameter		Description / Value	Unit
Arc size		1.0	mm
Window material		UV glass	—
Spectral distribution		185 to 2000	nm
Main discharge voltage variable range ①		400 to 600	V
Main discharge capacitance		0.141 0.094 0.047 0.02	μF
Maximum input energy (per flash)		See operating conditions.	mJ
Maximum average input (continuous)		See operating conditions.	W
Light output stability ②	Typ.	0.4	% CV
	Max.	2.0	% CV
Guaranteed life ③		1 × 10 ⁹	flashes
Operating time with battery		4 ④	h
Input voltage range		4.75 to 5.5, 10.8 to 13.2	V
Input current		1	A
Inrush current		1.5	A
Trigger input		Rectangular wave 2.5 V to 5 V; pulse width must be 10 μs or more. ⑤	—
Trigger input impedance		330	Ω
Cooling method		Not required ⑥	—
Weight	Standard type	Approx. 103	g
	SMA fiber adapter type	Approx. 108	g
Operating temperature range		0 to +40	°C
Storage temperature range		-40 to +90	°C
Operating humidity range		Below 85 % (no condensation)	—
Storage humidity range		Below 95 % (no condensation)	—
EMC standards		IEC61326-1: 2012 Group 1 Class B	—
Safety standards		IEC62471: 2006 Risk Group 3	—

NOTE:

- ① Internal: Adjustable with variable trimmer.
External: Variable with control voltage of 3.2 V to 4.8 V.
- ② Light output stability is given by:
Light output stability (% CV) = light output standard deviation / average light output × 100
(When repetition rate is 10 Hz or more.)
- ③ The life end is defined as the time when the light output at 190 nm to 1100 nm in 2 W operation falls below 50 % of the initial value or when the light output stability exceeds 20 % CV.
- ④ Time until the unit turns off.
(output and stability are not considered.)
Operating conditions
Input voltage: 5 V
Main discharge voltage: 600 V
Main discharge capacitance: 0.141 μF
Repetition rate: 79 Hz
Battery capacity: 5400 mAh/3.7 V
- ⑤ Only for external control; synchronized with rising edge.
- ⑥ Cooling is required when the package temperature exceeds 45 °C during operation.

VIBRATION AND SHOCK RESISTANCE

Resistance to vibration: 5 Hz to 200 Hz, 15 m/s²

Resistance to shock: 500 m/s²

OPERATING CONDITIONS

Type No.	Main discharge capacitance (μF)	Main discharge voltage (V)	Maximum ⑦ input energy [per flash] (mJ)	Maximum repetition rate ⑧ (Hz)		Maximum average input ⑨ (W)	
				Input voltage: 4.75 V to 5.5 V	Input voltage: 10.8 V to 13.2 V	Input voltage: 4.75 V to 5.5 V	Input voltage: 10.8 V to 13.2 V
L13651-□1	0.141	400	11.3	177	177	2.0	2.0
		500	17.7	113	113	2.0	2.0
		600	25.4	79	79	2.0	2.0
L13651-□2	0.094	400	7.5	266	266	2.0	2.0
		500	11.9	170	170	2.0	2.0
		600	16.9	118	118	2.0	2.0
L13651-□3	0.047	400	3.8	400	532	1.5	2.0
		500	5.9	255	340	1.5	2.0
		600	8.5	177	236	1.5	2.0
L13651-□4	0.02	400	1.6	625	1250	1.0	2.0
		500	2.5	400	800	1.0	2.0
		600	3.6	278	555	1.0	2.0

NOTE: ⑦ Maximum input energy (per flash)

$E = 1/2 CV^2$ C: Main discharge capacitance (F) V: Main discharge voltage (V)

⑧ In order to operate the unit with good stability, recommend repetition rate is 10 Hz or more.

⑨ Maximum average input (continuous)

$W = E \times f$ E: Maximum input energy (per flash) f: Repetition rate (Hz)

Ideal for installation into compact equipment

Lamp modules with increased freedom of design

L13821 series

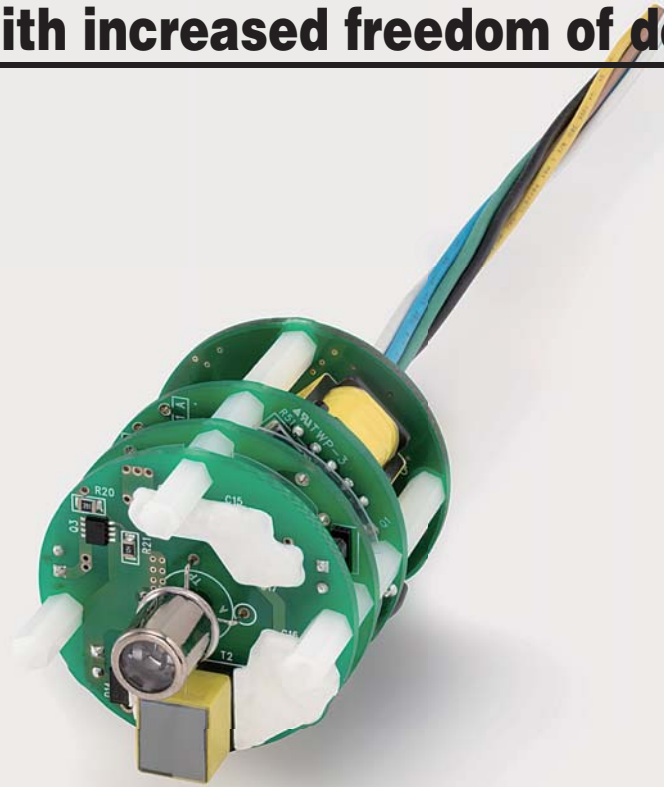

The L13821 series is a lamp module that consists of circular circuit boards stacked in a cylindrical shape, giving greater freedom of design while maintaining a high output, high stability, and long lifetime.

Further miniaturization and operation on a 5 V mobile battery allow installing the L13821 series into various types of portable, compact equipment such as for water quality inspections and a vast range of other applications.

TYPE NUMBER GUIDE

L13821 - 0 A

Type No.
Main discharge capacitance

A: Main discharge capacitance

Suffix	Capacitance
1	0.141 μF
2	0.094 μF
3	0.047 μF
4	0.02 μF

SPECTRAL IRRADIANCE (Typ.)

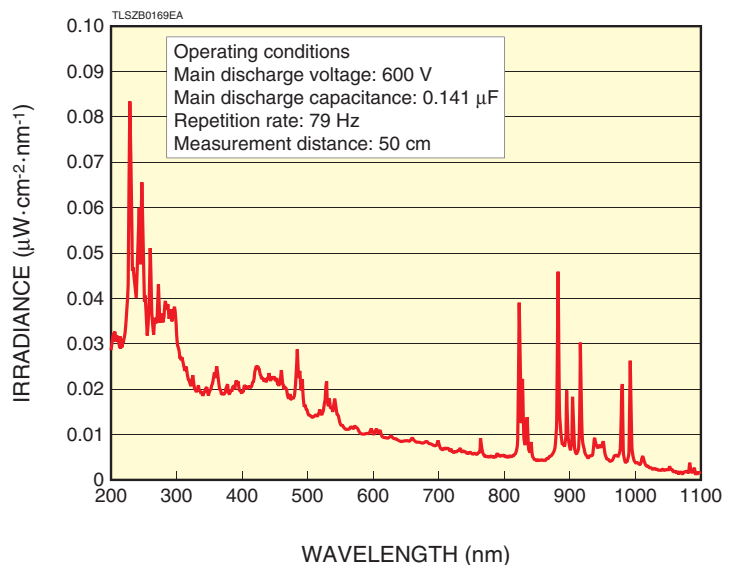

SPECIFICATIONS

Parameter	Description / Value	Unit
Arc size	1.0	mm
Window material	UV glass	—
Spectral distribution	185 to 2000	nm
Main discharge voltage variable range ①	400 to 600	V
Main discharge capacitance	0.141 0.094 0.047 0.02	μF
Maximum input energy (per flash)	See operating conditions.	mJ
Maximum average input (continuous)	See operating conditions.	W
Light output stability ②	Typ.	0.4 % CV
	Max.	2.0 % CV
Guaranteed life ③	1 × 10 ⁹	flashes
Operating time with battery	4 ④	h
Input voltage range	4.75 to 5.5, 10.8 to 13.2	V
Input current	1	A
Inrush current	1.5	A
Trigger input	Rectangular wave 2.5 V to 5 V; pulse width must be 10 μs or more. ⑤	—
Trigger input impedance	330	Ω
Cooling method	Not required ⑥	—
Weight	Approx. 42	g
Operating temperature range	0 to +40	°C
Storage temperature range	-40 to +90	°C
Operating humidity range	Below 85 % (no condensation)	—
Storage humidity range	Below 95 % (no condensation)	—
Safety standards	IEC62471: 2006 Risk Group 3	—

NOTE:

- ① Internal: Adjustable with variable trimmer.
External: Variable with control voltage of 3.2 V to 4.8 V.
- ② Light output stability is given by:
Light output stability (% CV) = light output standard deviation / average light output × 100
(When repetition rate is 10 Hz or more.)
- ③ The life end is defined as the time when the light output at 190 nm to 1100 nm in 2 W operation falls below 50 % of the initial value or when the light output stability exceeds 20 % CV.
- ④ Time until the unit turns off.
(output and stability are not considered.)
Operating conditions
Input voltage: 5 V
Main discharge voltage: 600 V
Main discharge capacitance: 0.141 μF
Repetition rate: 79 Hz
Battery capacity: 5400 mAh/3.7 V
- ⑤ Only for external control; synchronized with rising edge.
- ⑥ Cooling is required when the package temperature exceeds 45 °C during operation.

VIBRATION AND SHOCK RESISTANCE

Resistance to vibration: 5 Hz to 200 Hz, 15 m/s²

Resistance to shock: 500 m/s²

OPERATING CONDITIONS

Type No.	Main discharge capacitance (μF)	Main discharge voltage (V)	Maximum ⑦ input energy [per flash] (mJ)	Maximum repetition rate ⑧ (Hz)		Maximum average input ⑨ (W)	
				Input voltage: 4.75 V to 5.5 V	Input voltage: 10.8 V to 13.2 V	Input voltage: 4.75 V to 5.5 V	Input voltage: 10.8 V to 13.2 V
L13821-01	0.141	400	11.3	177	177	2.0	2.0
		500	17.7	113	113	2.0	2.0
		600	25.4	79	79	2.0	2.0
L13821-02	0.094	400	7.5	266	266	2.0	2.0
		500	11.9	170	170	2.0	2.0
		600	16.9	118	118	2.0	2.0
L13821-03	0.047	400	3.8	400	532	1.5	2.0
		500	5.9	255	340	1.5	2.0
		600	8.5	177	236	1.5	2.0
L13821-04	0.02	400	1.6	625	1250	1.0	2.0
		500	2.5	400	800	1.0	2.0
		600	3.6	278	555	1.0	2.0

NOTE: ⑦ Maximum input energy (per flash)

$E=1/2 CV^2$ C: Main discharge capacitance (F) V: Main discharge voltage (V)

⑧ In order to operate the unit with good stability, recommend repetition rate is 10 Hz or more.

⑨ Maximum average input (continuous)

$W=E \times f$ E: Maximum input energy (per flash) f: Repetition rate (Hz)

CHARACTERISTICS

● LIGHT OUTPUT STABILITY (Typ.)

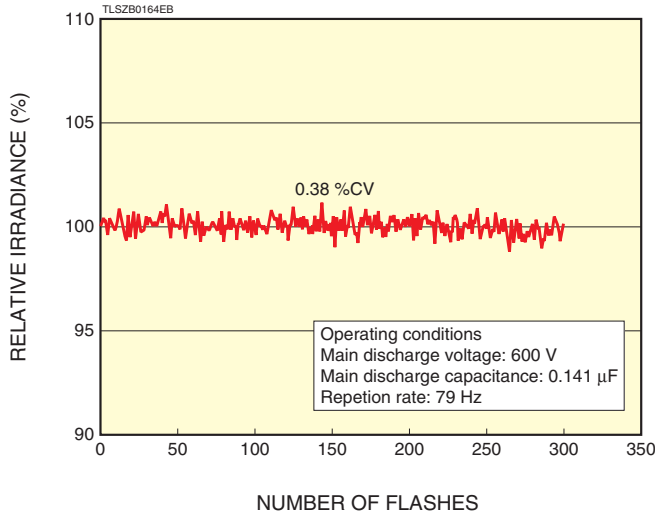

Measuring block diagram

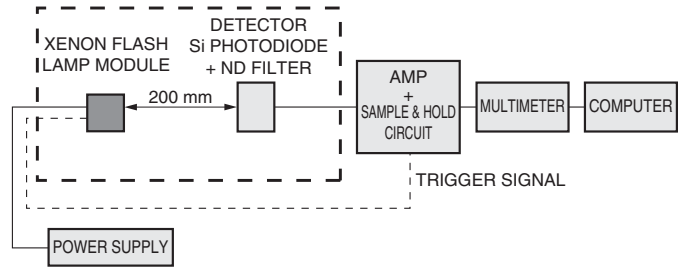

TLSZC0022EA

● LIFE CHARACTERISTICS (Typ.)

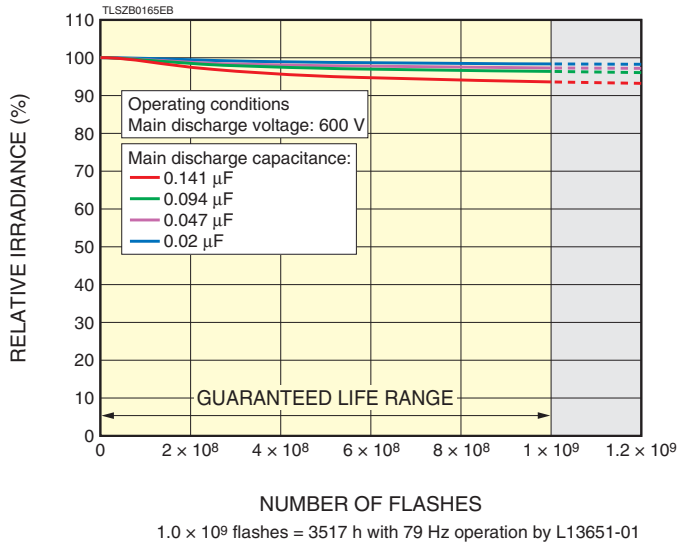

● EMISSION PULSE WAVEFORMS (Typ.)

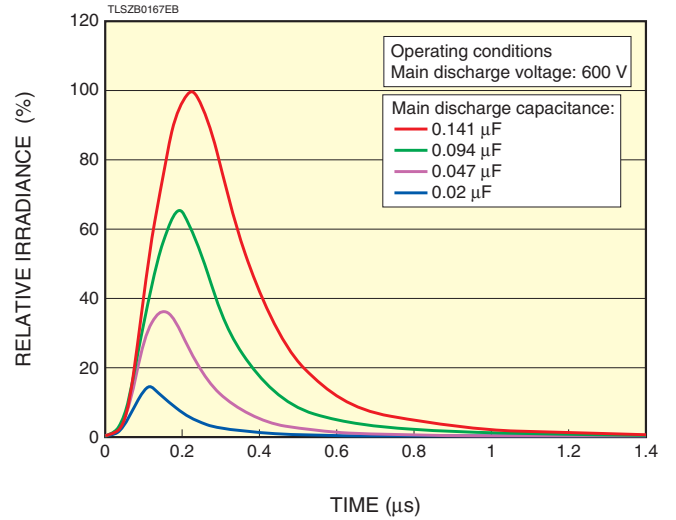

● DIRECTIVITY (LIGHT DISTRIBUTION) (Typ.)

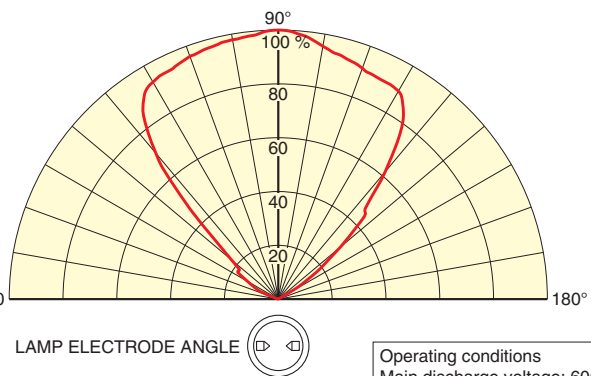
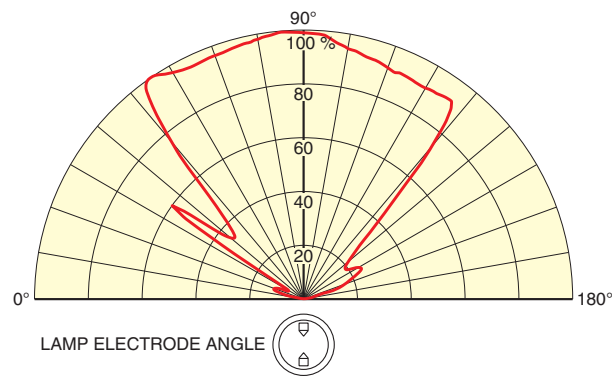

Operating conditions
Main discharge voltage: 600 V
Main discharge capacitance: 0.141 μF
Repetition rate: 50 Hz
Measurement distance: 50 cm

TLSZB0168EB

DIMENSIONAL OUTLINES (Unit: mm)

●L13651 SERIES

STANDARD TYPE

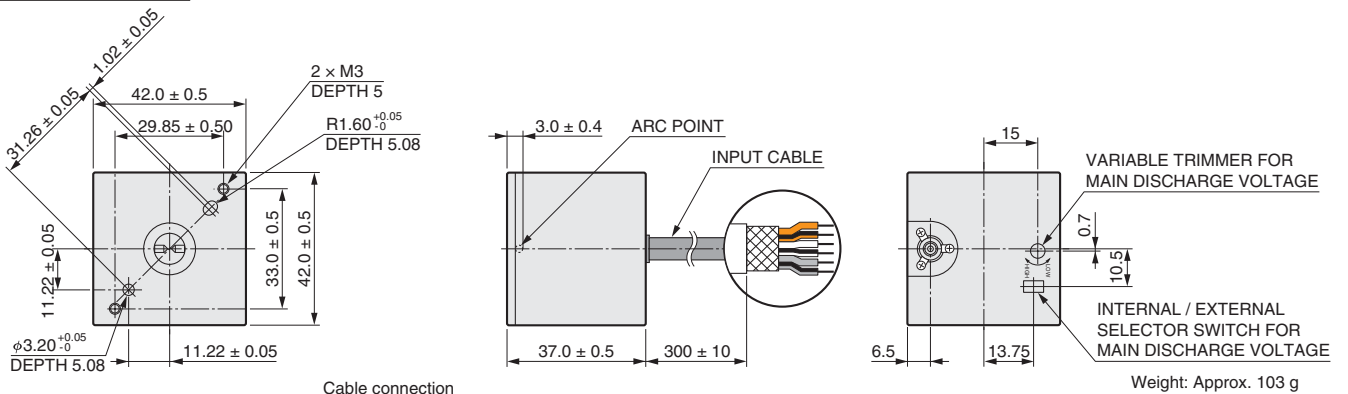

Cable connection

Color	Signal
Orange	+ input voltage (4.75 V to 5.5 V, 10.8 V to 13.2 V)
Orange + Black	Input voltage RTN.
White	+ trigger input
White + Black	Trigger input RTN.
Gray	+ main discharge voltage control (3.2 V to 4.8 V)
Gray + Black	Main discharge voltage control RTN.

* For this product, the reference potential (0 V) is not marked as GND, but marked as RTN.. This is because we recommend connecting the cable wires by separating them from the GND. line in order to avoid the effects of external noise on trigger signals.

TLSZA0048EB

Weight: Approx. 103 g

SMA FIBER ADAPTER TYPE

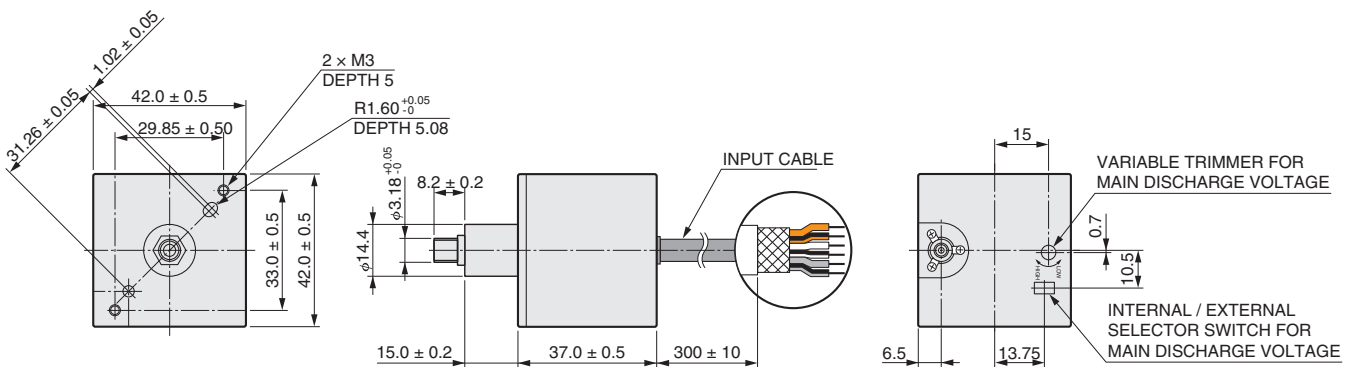

Cable connection

Color	Signal
Orange	+ input voltage (4.75 V to 5.5 V, 10.8 V to 13.2 V)
Orange + Black	Input voltage RTN.
White	+ trigger input
White + Black	Trigger input RTN.
Gray	+ main discharge voltage control (3.2 V to 4.8 V)
Gray + Black	Main discharge voltage control RTN.

* For this product, the reference potential (0 V) is not marked as GND, but marked as RTN.. This is because we recommend connecting the cable wires by separating them from the GND. line in order to avoid the effects of external noise on trigger signals.

TLSZA0049EB

Weight: Approx. 108 g

●L13821 SERIES

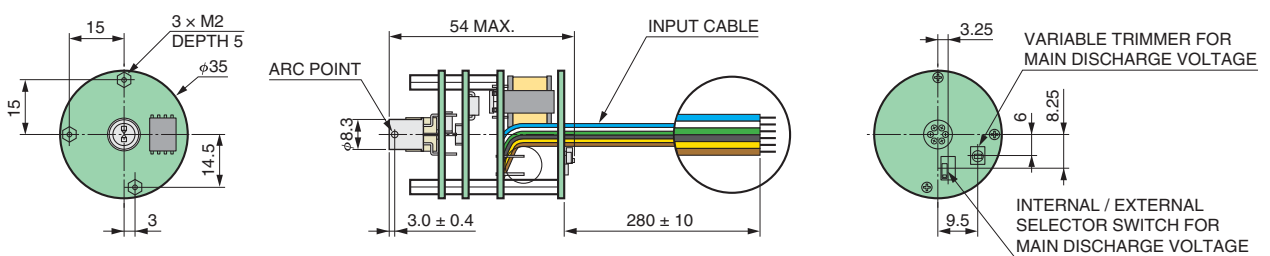

Cable connection

Color	Signal
Blue	+ input voltage (4.75 V to 5.5 V, 10.8 V to 13.2 V)
White	Input voltage RTN.
Green	+ trigger input
Black	Trigger input RTN.
Yellow	+ main discharge voltage control (3.2 V to 4.8 V)
Brown	Main discharge voltage control RTN.

* For this product, the reference potential (0 V) is not marked as GND, but marked as RTN.. This is because we recommend connecting the cable wires by separating them from the GND. line in order to avoid the effects of external noise on trigger signals.

TLSZA0050EA

Weight: Approx. 42 g

Subject to local technical requirements and regulations, availability of products included in this promotional material may vary. Please consult with our sales office.
Information furnished by HAMAMATSU is believed to be reliable. However, no responsibility is assumed for possible inaccuracies or omissions. Specifications are subject to change without notice. No patent rights are granted to any of the circuits described herein. ©2019 Hamamatsu Photonics K.K.

HAMAMATSU PHOTONICS K.K. www.hamamatsu.com

HAMAMATSU PHOTONICS K.K., Electron Tube Division

314-5, Shimokanzo, Iwata City, Shizuoka Pref., 438-0193, Japan, Telephone: (81)539/62-5248, Fax: (81)539/62-2205

U.S.A.: Hamamatsu Corporation: 360 Foothill Road, Bridgewater, NJ 08807, U.S.A., Telephone: (1)908-231-0960, Fax: (1)908-231-1218 E-mail: usa@hamamatsu.com

Germany: Hamamatsu Photonics Deutschland GmbH.: Arzbergerstr. 10, D-82211 Herrsching am Ammersee, Germany, Telephone: (49)8152-375-0, Fax: (49)8152-265-8 E-mail: info@hamamatsu.de

France: Hamamatsu Photonics France S.A.R.L.: 19, Rue du Saule Trapu, Parc du Moulin de Massy, 91882 Massy Cedex, France, Telephone: (33)1 69 53 71 00, Fax: (33)1 69 53 71 10 E-mail: infos@hamamatsu.fr

United Kingdom: Hamamatsu Photonics UK Limited: 2 Howard Court, 10 Tewin Road, Welwyn Garden City, Hertfordshire AL7 1BW, UK, Telephone: (44)1707-294888, Fax: (44)1707-325777 E-mail: info@hamamatsu.co.uk

North Europe: Hamamatsu Photonics Norden AB: Torshamnsgatan 35 16440 Kista, Sweden, Telephone: (46)8-509 031 00, Fax: (46)8-509 031 01 E-mail: info@hamamatsu.se

Italy: Hamamatsu Photonics Italia S.r.l.: Strada della Moia, 1 int. 6, 20020 Arese (Milano), Italy, Telephone: (39)02-93 58 17 33, Fax: (39)02-93 58 17 41 E-mail: info@hamamatsu.it

China: Hamamatsu Photonics (China) Co., Ltd.: 1201 Tower B, Jiaming Center, 27 Dongsanhuan Bellu, Chaoyang District, 100020 Beijing, P.R.China, Telephone: (86)10-6586-6006, Fax: (86)10-6586-2866 E-mail: hpc@hamamatsu.com.cn

Taiwan: Hamamatsu Photonics Taiwan Co., Ltd.: 8F-3, No.158, Section2, Gongdao 5th Road, East District, Hsinchu, 300, Taiwan R.O.C. Telephone: (886)3-659-0080, Fax: (886)3-659-0081 E-mail: info@hamamatsu.com.tw

TLSZ1030E04
JUL. 2019 IP